

TULLE BAR CHAIR  
ASSEMBLY INSTRUCTIONS

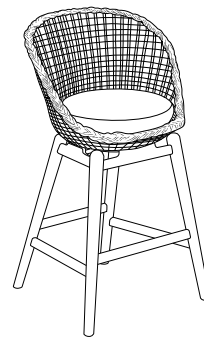

**COMPONENTS**

---

- ① Tulle Bar Chair - Leg Assembly  
Quantity: 1

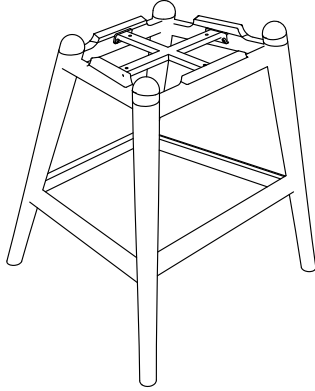

- ② Tulle Bar Chair - Seat  
Quantity: 1

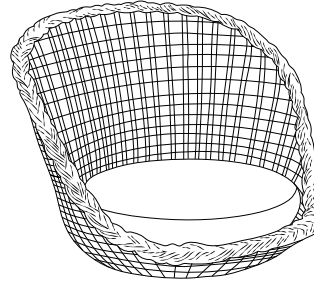

**HARDWARE**

---

- Ⓐ Short Machine Bolt  
Quantity: 4



- Ⓑ Allen Wrench  
Quantity: 1

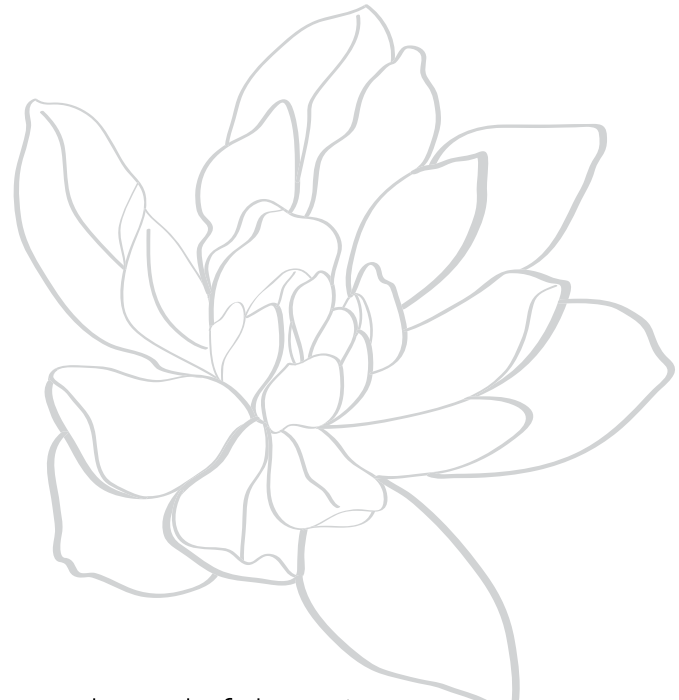
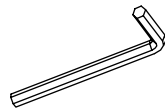

Thoughtful Design **MADE RIGHT**

# INSTRUCTIONS

## STEP 1

Lay seat ① upside down on top of provided cardboard box or blanket to protect the surface of the chair while assembling.

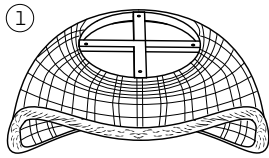

## STEP 2

Align leg assembly ② to seat as shown. Insert the 4 bolts A through the leg assembly and gently tighten bolts by hand. DO NOT OVERTIGHTEN.

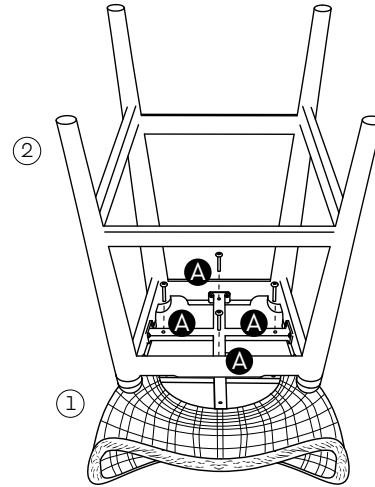

## STEP 2 DETAIL

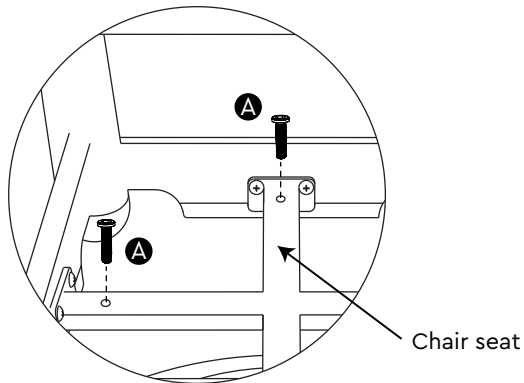

## STEP 3

Using the Allen Wrench B carefully tighten the 4 bolts A a little at a time until the Leg Assembly ② is secure.

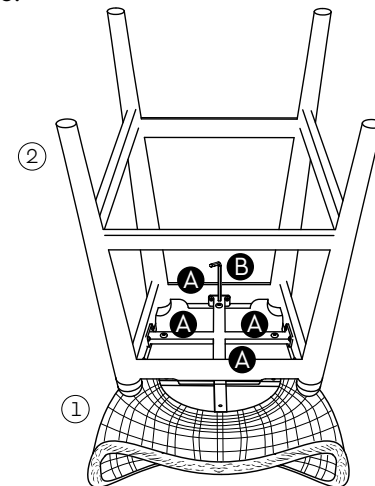

## STEP 4

Turn the chair upright and enjoy!

