

SIENA LOVESEAT - S52

ASSEMBLY INSTRUCTIONS

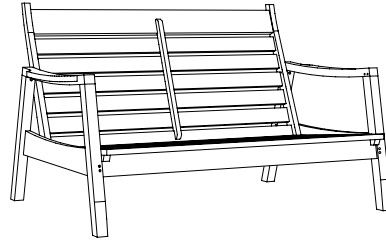

COMPONENTS

① Table Top
Quantity: 1

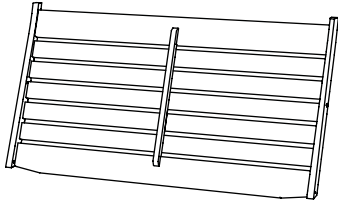

② Seat
Quantity: 1

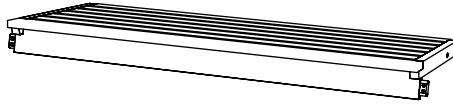

③ Right Leg
Quantity: 1

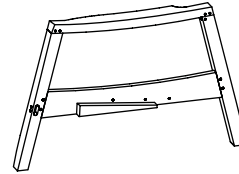

④ Left Leg
Quantity: 1

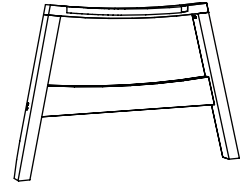

HARDWARE

A Long Bolt
Quantity: 2



B Short M6 x 35 mm Bolt
Quantity: 6



C Guiding Bolt
Quantity: 1



D Barrel Nut
Quantity: 1



E 8mm Dowel
Quantity: 12

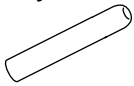

F Wood Screw
Quantity: 1



G Allen Wrench
Quantity: 2

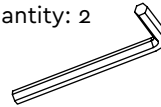

FINISHING ITEMS

Medium Grit Sandpaper

Note: Hardware pack may contain extra hardware

NOTE: If the furniture is going to be placed on a concrete or tile patio, it should first be rinsed well to remove the sawdust that may cause some staining.



Thoughtful Design **MADE RIGHT**

INSTRUCTIONS

STEP 1

Two Person Assembly Recommended

NOTE: This item uses tight tolerances, it is important to follow the steps in the order shown here.

Lay leg assembly (4) on flat surface and insert back assembly (1)

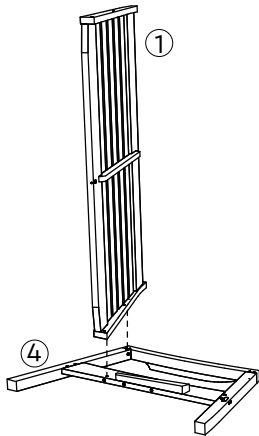

STEP 3

Next, insert the seat assembly (2) into the rest of the assembled parts.

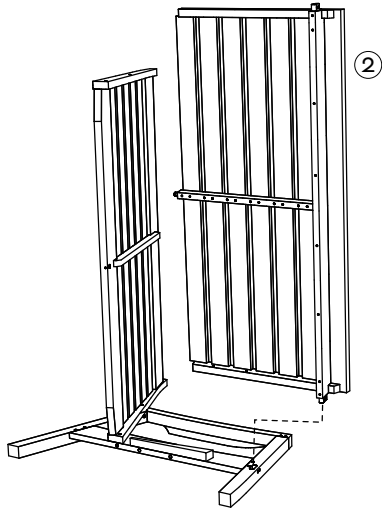

STEP 5

Insert the remaining leg assembly into the assembled parts and repeat steps 2 and 4 to secure. Next, further secure the seat to the leg assemblies by driving two dowels (E) into the mortise holes as shown.

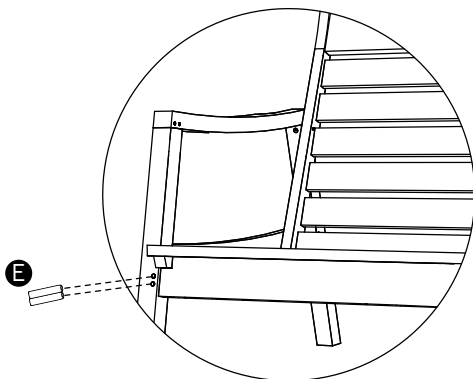

How to align barrel nuts and bolts.

Insert a guiding bolt into the end of a barrel nut. Align the barrel nut inside of the component with the bolt used to connect the components. Once the component bolt is aligned and threaded, simply pull the guiding bolt from the end of the barrel nut.

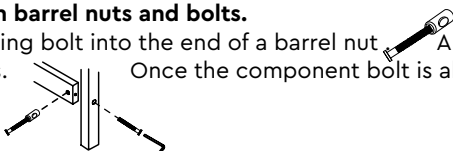

STEP 2

See bottom notes on how to align barrel nuts and bolts.

Using the provided allen wrench and guiding bolt (C), secure TOP of the back with barrel nut (D) and LONG bolt (A) as shown. Secure BOTTOM of the back as shown using barrel nut and SHORT bolt (B).

NOTE: Do not tighten down in this step, leave loose until all bolts are inserted, then tighten all bolts. Be certain not to over tighten.

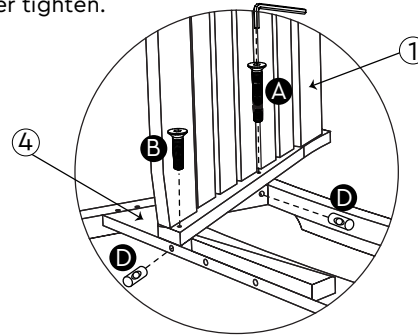

STEP 4

Using the provided allen wrench and guiding bolt (C), secure seat with barrel nut (D) and SHORT bolt (B) as shown.

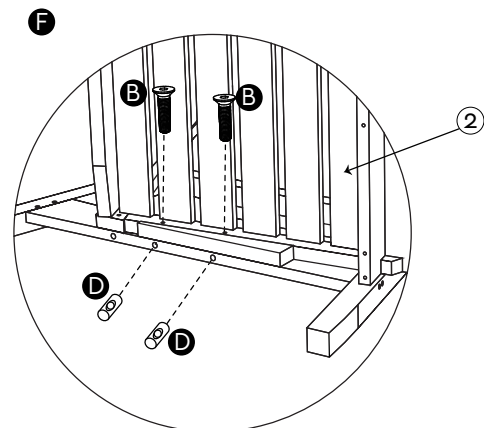

Step 6

Lastly, go back and tighten all the bolts inserted previously and insert one wood screw (F) into the seat assembly as shown.

