

SIENA CLUB CHAIR - SCC

ASSEMBLY INSTRUCTIONS

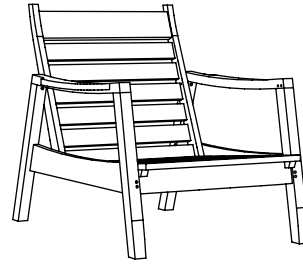

COMPONENTS

① Back
Quantity: 1

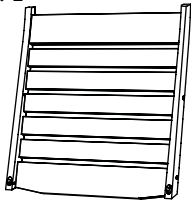

② Seat
Quantity: 1



③ Right Leg
Quantity: 1

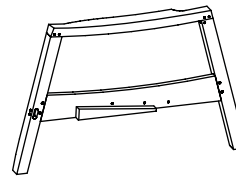

④ Left Leg
Quantity: 1

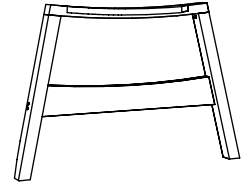

HARDWARE

A Long Bolts
Quantity: 2



B Short Bolts
Quantity: 6



C Guiding Bolt
Quantity: 1



D Barrel Nut
Quantity: 8



E Dowels
Quantity: 4

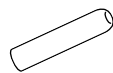

F Allen Wrench
Quantity: 1

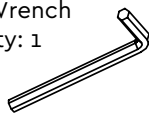

FINISHING ITEMS

Medium Grit Sandpaper

NOTE: If the furniture is going to be placed on a concrete or tile patio, it should first be rinsed well to remove the sawdust that may cause some staining.

NOTE: Hardware pack may contain extra hardware

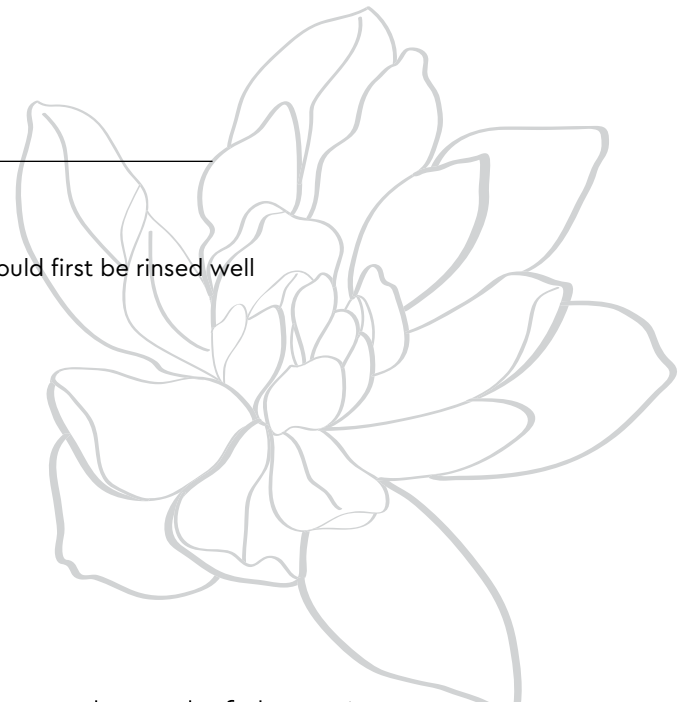

Thoughtful Design **MADE RIGHT**

INSTRUCTIONS

STEP 1

NOTE: This item uses tight tolerances, it is important to follow the steps in the order shown here. Lay leg assembly ④ on flat surface and insert back assembly ① as shown.

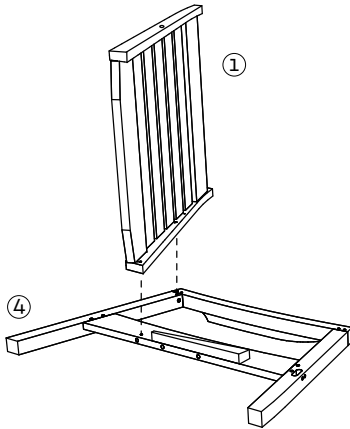

STEP 2

See bottom notes on how to align barrel nuts and bolts. Using the provided allen wrench and guiding bolt ③, secure TOP of the back with barrel nut ④ and LONG bolt ⑤ as shown. Secure BOTTOM of the back as shown using barrel nut and SHORT bolt ⑥.

NOTE: Do not tighten down in this step, leave loose until all bolts are inserted, then tighten all bolts. Be certain not to over tighten.

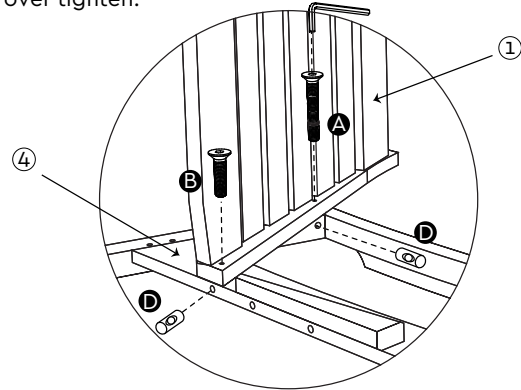

STEP 3

Next, insert the tenons on the seat assembly ② into the leg assembly as shown.

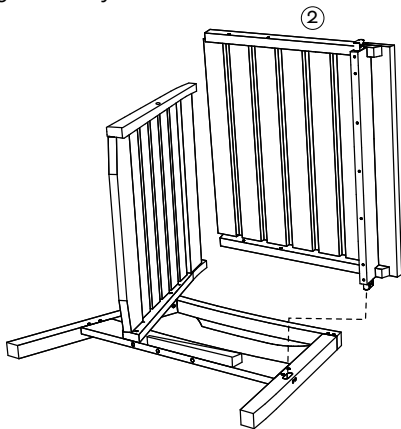

STEP 4

Using the provided allen wrench and guiding bolt ③, secure seat with barrel nut ④ and SHORT bolt ⑥ as shown.

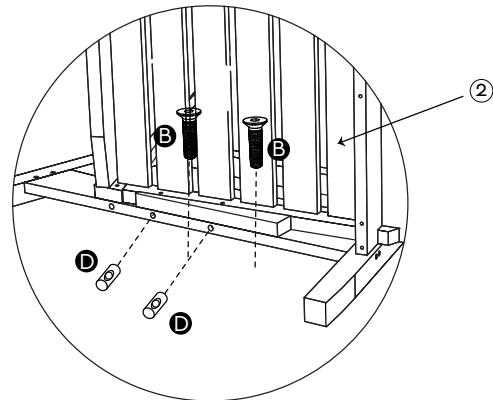

STEP 5

Insert the remaining leg assembly into the assembled parts and repeat steps 2 and 4 to secure. Next, further secure the seat to the leg assemblies by driving two dowels ⑦ into the mortise holes as shown.

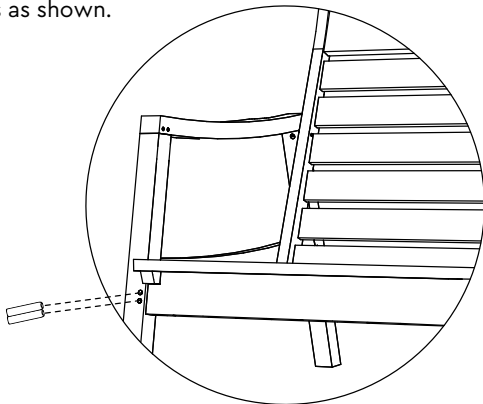

How to align barrel nuts and bolts.

Insert a guiding bolt into the end of a barrel nut. Align the barrel nut inside of the component with the bolt used to connect the components. Once the component bolt is aligned and threaded, simply pull the guiding bolt from the end of the barrel nut.

