

ESSEX BENCH - 6'

ASSEMBLY INSTRUCTIONS

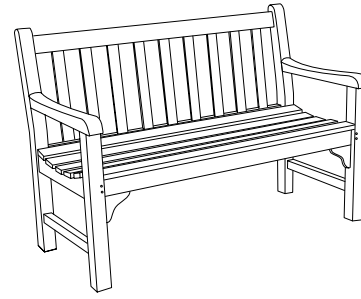

COMPONENTS

① Right Arm Assembly  
Quantity: 1

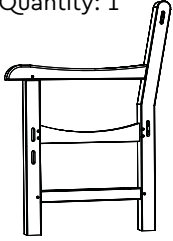

② Left Arm Assembly  
Quantity: 1

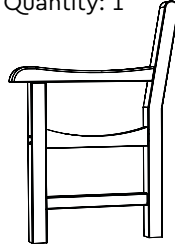

③ Back  
Quantity: 1

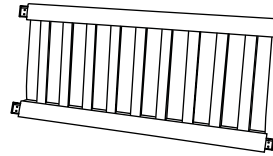

④ Seat  
Quantity: 1

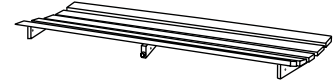

⑤ Right Corner Brace  
Quantity: 1

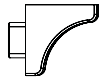

⑥ Left Corner Brace  
Quantity: 1



⑦ Front Rail  
Quantity: 1



HARDWARE

A Dowels  
Quantity: 18



B Phillip-Head Wood Screws  
Quantity: 8



C Allen Head Wood Screws  
Quantity: 2



D Allen Wrench  
Quantity: 1

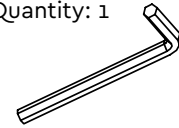

FINISHING ITEMS

Medium Grit Sandpaper

NOTE: If the furniture is going to be placed on a concrete or tile patio, it should first be rinsed well to remove the sawdust that may cause some staining.

NOTE: A hammer and a phillips head screwdriver (not provided) will be needed for the assembly of this bench.

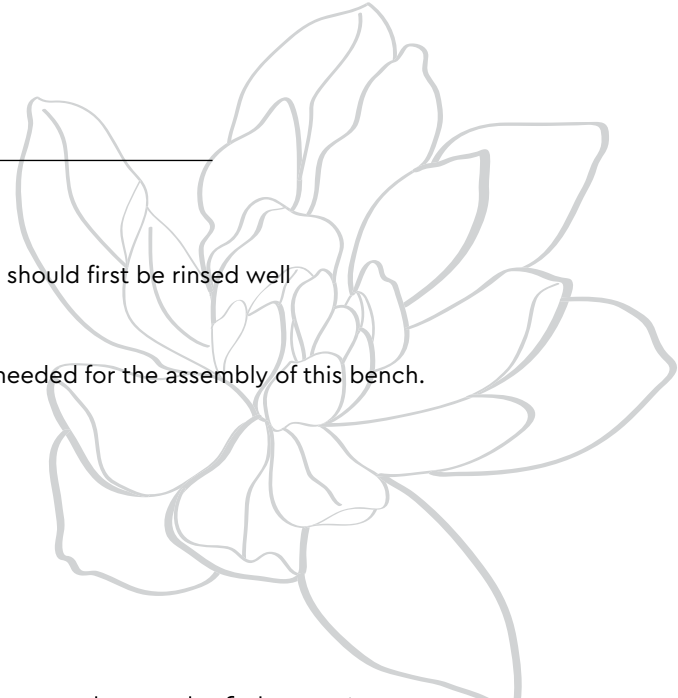

Thoughtful Design **MADE RIGHT**

# INSTRUCTIONS

## STEP 1

On a clean flat surface, lay right arm assembly ① on its side mortise holes facing up. Place the back ③ into the mortise of the right arm assembly.

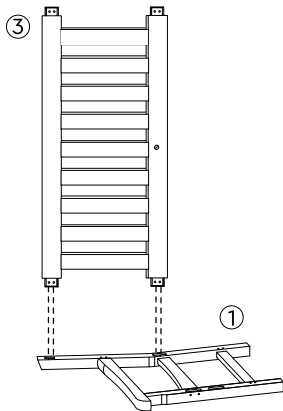

## STEP 2

Locate the small label on the bottom of the seat that reads "front". With the front of the seat toward the front of the bench, line up and insert the front rail ⑦ and seat ④ into the right arm assembly. Insert the large rounded pegs at the front and rear of the seat into the back and front rail.

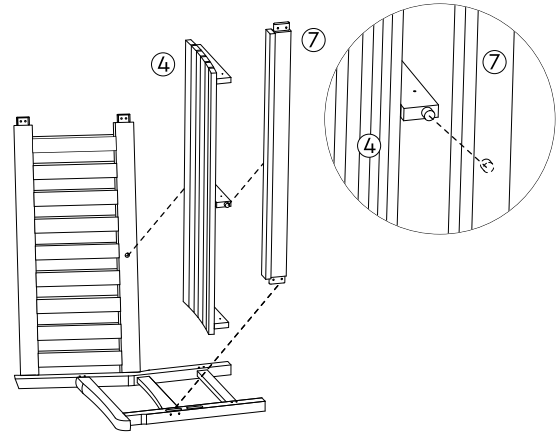

## STEP 3

Line up and place left arm assembly ② onto those parts already assembled. Next, with a hammer drive 4 dowels A into the predrilled holes found on the front of the leg assemblies to hold the front rail into place. Drive the remaining 8 dowels into the predrilled holes located on the back of the leg assemblies to hold the back in place.

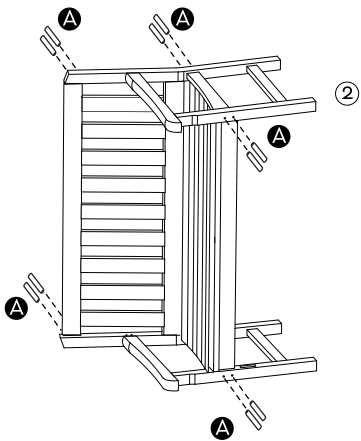

## STEP 4

Using a phillips head screwdriver, screw the 6 total wood screws B into the predrilled holes on the underside of the seat to attach the seat to the seat back, front rail and arm assemblies as shown.

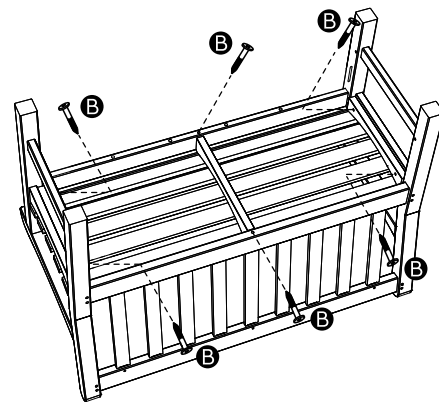

## STEP 5

Secure corner brace ⑤ with the allen head screw C using the allen wrench provided. Repeat for the remaining corner brace.

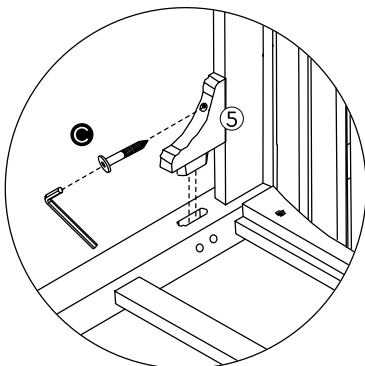

## STEP 6

To further secure the corner brace drive 2 dowels A into the predrilled holes as shown. Repeat for the remaining corner brace.

